



STUDIO  
**BOVTI**

ASTA TONDA  
DATASHEET

# ASTA TONDA - STOOL



## FACTS

Object Type:	stool
Composition:	walnut , leather
Dimensions:	56 x 41 x 46 cm
Colour:	brown, green
Lead Time:	6-8 weeks
Customization:	available
Weight:	3 kg
Editions:	open edition, numbered and signed

## USAGE INSTRUCTIONS

Astatonda is a beautifully crafted chair and pouf made from oak and walnut wood, complemented by natural leather. To maintain its quality and appearance, please follow these guidelines:

**Cleaning:** Use a soft, dry cloth to dust the surfaces regularly. For deeper cleaning, lightly dampen the cloth with water or a mild soap solution, and wipe the wood surfaces. Avoid soaking the leather or wood.

**Avoid Direct Sunlight:** Prolonged exposure to strong sunlight may cause discoloration or changes in the wood and leather over time.

**Handling:** Lift and move Astatonda with care, holding it by the sturdy parts of the structure.

### Wood and Leather Care:

Avoid excessive moisture, as it can damage both the wood and leather. Wipe up spills promptly and do not expose Astatonda to high humidity. For leather, avoid using harsh chemicals or abrasive materials that could scratch or damage the surface. Consider using a leather conditioner periodically to keep the material supple and protected. Periodically check the joints and connections to ensure stability and longevity.



## DIMENSIONS

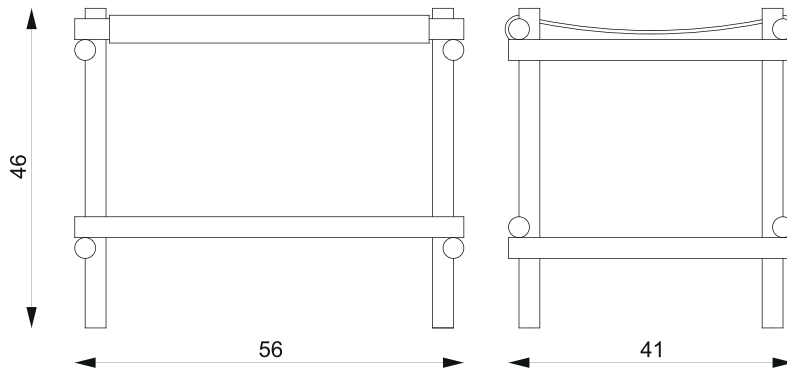
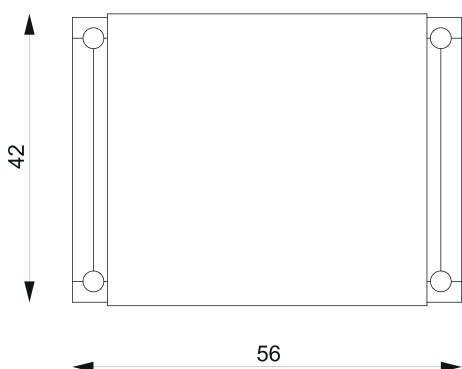

# ASTA TONDA - CHAIR



## FACTS

Object Type:	lounge chair
Composition:	walnut , leather
Dimensions:	62 x 56 x 78 cm
Colour:	brown, green
Lead Time:	6-8 weeks
Customization:	available
Weight:	4 kg
Editions:	open edition, numbered and signed

## USAGE INSTRUCTIONS

Astatonda is a beautifully crafted chair and pouf made from oak and walnut wood, complemented by natural leather. To maintain its quality and appearance, please follow these guidelines:

**Cleaning:** Use a soft, dry cloth to dust the surfaces regularly. For deeper cleaning, lightly dampen the cloth with water or a mild soap solution, and wipe the wood surfaces. Avoid soaking the leather or wood.

**Avoid Direct Sunlight:** Prolonged exposure to strong sunlight may cause discoloration or changes in the wood and leather over time.

**Handling:** Lift and move Astatonda with care, holding it by the sturdy parts of the structure.

### Wood and Leather Care:

Avoid excessive moisture, as it can damage both the wood and leather. Wipe up spills promptly and do not expose Astatonda to high humidity. For leather, avoid using harsh chemicals or abrasive materials that could scratch or damage the surface. Consider using a leather conditioner periodically to keep the material supple and protected. Periodically check the joints and connections to ensure stability and longevity.



## DIMENSIONS

